

OPERATING INSTRUCTIONS

Automatic Number, Date & Time Stamps
Automatic Date Stamps & Validators
Lever Set Numbering Machines
Automatic Number Stamps
Automatic Time Stamps
Automatic Stamps
Check Certifiers
Check Signers

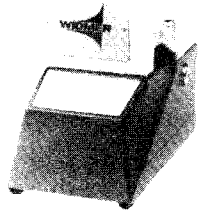
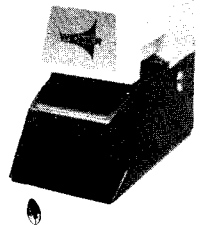

WIDMER

TIME RECORDER CO., INC.

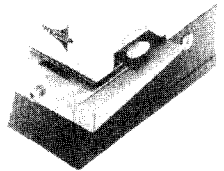
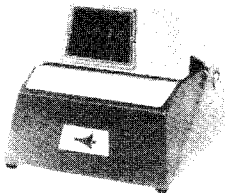

OPERATING INSTRUCTIONS FOR WIDMER AUTOMATIC RECORDERS

MODEL SERIES: S T. T-LED. N. ND. D. DN. O. R. 776. CC & OSL

Please check the current voltage and cycles on the specification plate at the rear of the machine to be certain that these conform with the power sources that you intend using.

Please record the serial number, model number and key number for future reference.

Serial # _____

Model # _____

Key # _____

TO OBTAIN AN IMPRINT — Close and lock the case and insert the plug in the proper grounded receptical. Place the paper in the slot between the upper and lower castings; the paper will trigger the automatic stamping mechanism.

Caution: Do not insert extra thick documents as this will cause the machine to malfunction. If jamming occurs, immediately disconnect the plug from the receptical, remove the thick document, then reconnect the plug.

LUBRICATION AND MAINTENANCE — Machines are fully lubricated when leaving the factory and will only need a drop or two of high-grade business machine oil about once or twice a year on all moving parts. Do not get oil on the ribbon or other non-metal and electrical parts. Do not oil excessively or this could clog the mechanism. A good clear imprint can be maintained by occasionally cleaning the type wheels and dies with a typewriter brush or rag; do not use cleaning fluids. The case can be cleaned by wiping with a mild detergent and water occasionally.

Caution; REMEMBER TO UNPLUG THE MACHINE WHENEVER YOU ARE WORKING ON IT.

To set the print wheels:

TIME STAMP — Insert case key in lock and rotate key towards you. Lift up the top of the machine and set the wheels by using a wooden stylus or pencil to rotate the wheels in a downward direction; setting each wheel to the time and date you desire. Please be sure that the A-P wheel is set correctly or else the date will change at 12 noon instead of 12 midnight. At the first of each month please reset the date and month wheels and on the first day of the new year, the year wheel. See fig. 1.

NUMBERING MACHINES — Rotate the wheels downward and always set the number to 1 digit lower than the number that you wish to print. For example: to print the number 000001, set the machine to 000000. Only the first six digits of any numbering machine work automatically. Additional wheels and date wheels must be manually set. On numbering machines with the AC numbering advance, please set the number to the digits that you wish to print. For example: To print the number 12 set the machine to number 12.

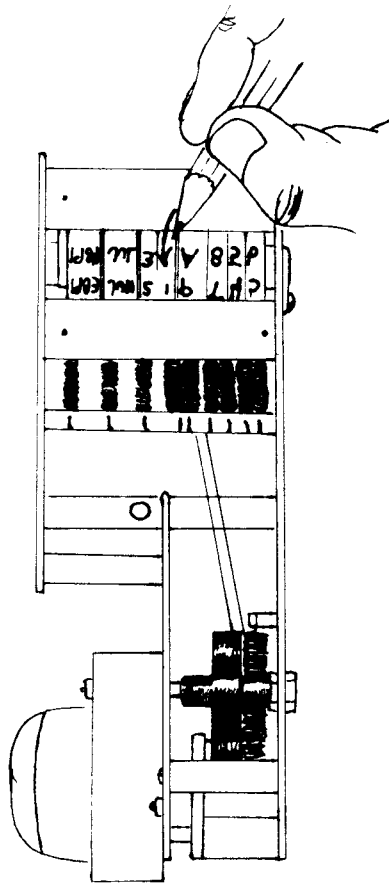

figure 1

To set the LED digital clock face:

Please Note: If you choose a unit with the LED digital clock face accessory, the display has been improved to provide larger characters and a simplified way to synchronize the display with the print wheels.

Locate the 3 clock face setting buttons in front of the print wheels and behind the clock face. The buttons reading from left to right are: fast set, slow set and hold. *Fig. 2*

Using the fast set button, advance the display to within a few minutes of the actual time desired, then press the slow set buttons and advance the time to the same minute that you have set on the print wheels. If you wish to synchronize the digital display with the print wheels, proceed as follows: Using the slow set button, advance the time to 1 minute beyond the time set on the print wheels. For example if the print wheels are set at 12:00 P.M., time display would be advanced to 12:01. To synchronize the face with the print wheels, depress the hold button and continue to hold it in until you hear the click of the print wheels changing. When you hear this click immediately release the hold button. Your LED is now synchronized with the print wheels.

figure 2

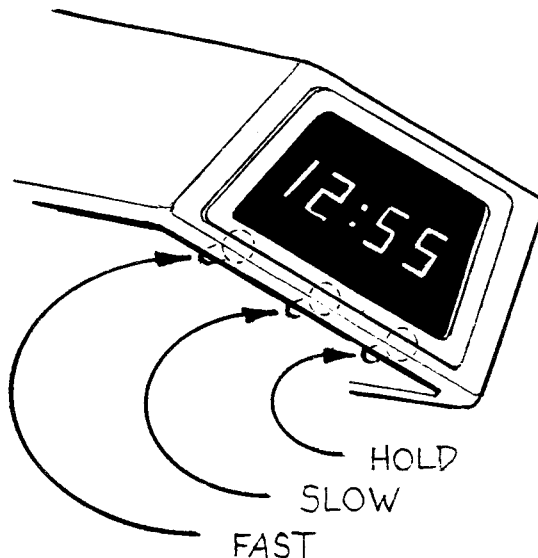

MODEL CC; CHECK CERTIFIER — The Model CC Check Certifier sets the same as the numbering machines Model N and Model ND. Please see those instructions.

DATE STAMPS — Date stamps are set the same way as time stamps, only on a daily basis. Please note that on some models, namely the DRSU removable die models, there is a red lever (See *fig. 3*), located below and to the left of the print wheels that must be depressed and held while advancing the wheels. The date wheels do not advance automatically on any of these models.

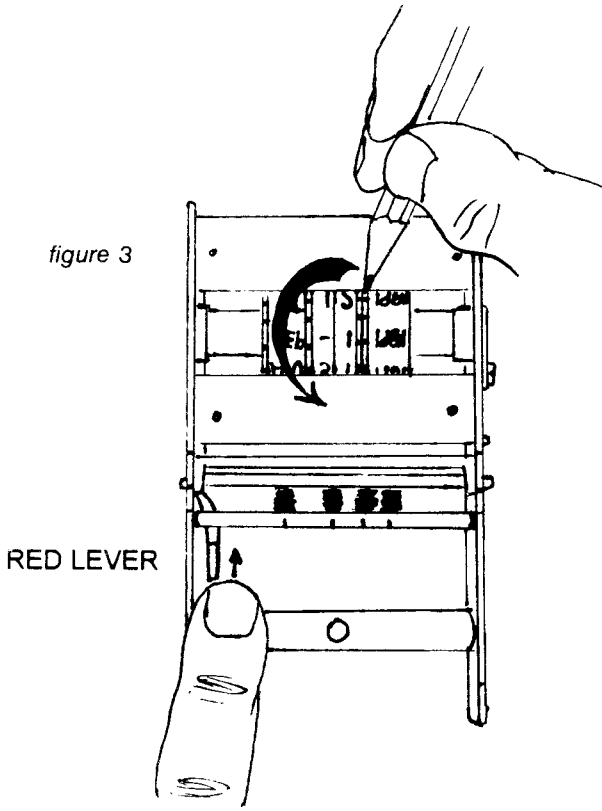

AUTOMATIC STAMPS; MODELS O & R — These machines do not encompass any wheels. The model O imprints fixed die information only which is screwed into the machine. The model R also prints fixed die information. However, the die can be removed by depressing the red lever located below and to the left of the engraved die plates on the machine. Depressing the lever (See *fig. 4*) will release spring clips which will allow you to remove the die plate and substitute another die.

AUTOMATIC CHECKSIGNER; MODEL S. The Model S is equipped with unique keys for the case and security lock. Please make sure you record the serial numbers of both the case lock and the unique key for the security lock. The security counter on the Model S is a non-resettable counter. Please log the number at the start and completion of each check run and verify the number of checks that have been stamped on the machine. The die plate can be easily removed by inserting the case key, rotating forward towards you and lifting the top of the case. Below the upper frame assembly is a release lever marked "Push Lever" (See Fig. 4). When inserting or removing the signature, grasp the die plate holder by the convenient handle, depress and hold the release lever and slide the plate along the dove tail rails in the direction indicated.

The Model S is also equipped with an adjustable guide shelf. The shelf can be moved Left or Right to accommodate your check by simply loosening the knob on the front of the machine and sliding the shelf to the proper location for your check. In most cases, the shelf is preset for your check when shipped from the factory. If your forms are not accommodated by the standard guide, custom built shelves are available, either fixed or adjustable, on special quotation.

The adjustable guide in conjunction with a square signature plate which can be mounted to the holder in any of four directions, allows the flexibility to accommodate almost any check.

figure 4

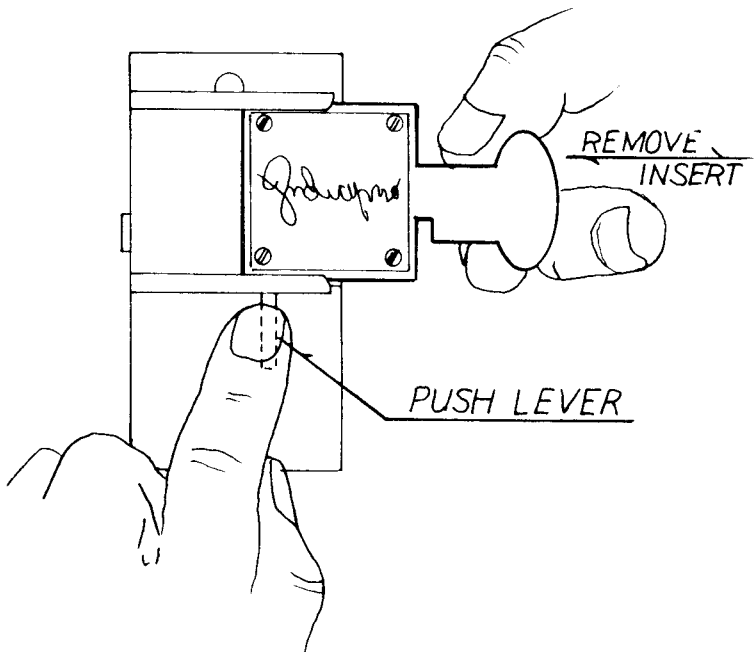

TO CHANGE THE RIBBON — On all models except 776 series, lift ribbon feeler A and slide ribbon B off shaft C. Accomplish this on both the front rear ribbon feelers. Replace with the Model 1000 ribbon, being sure to place the spools under the ribbon feeler. See *fig. 5*.

Warning: Never attempt to re-ink ribbons, this will only clog the wheel and cause a failure of the machines' operations.

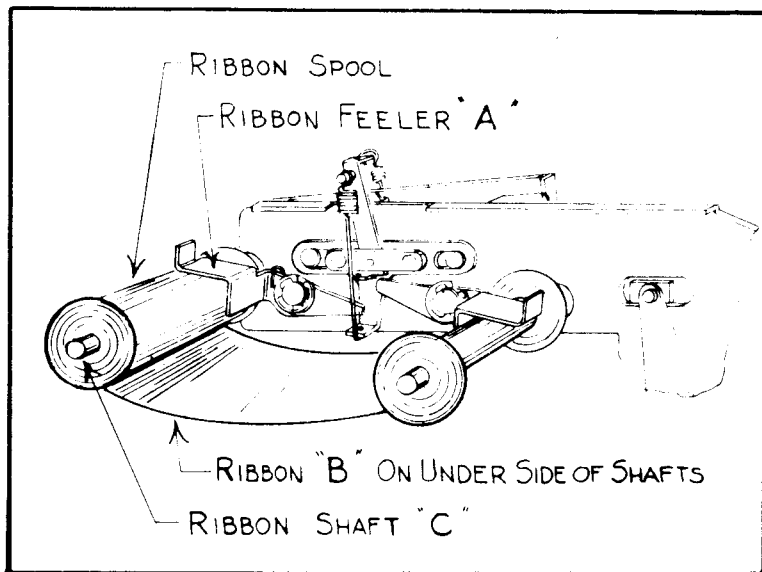

figure 5

Model 776 ribbon change is different from other models. The 776 uses a double ribbon and the spool has consecutive circles which should always be on the left side of the machine next to the ribbon transport levers. To change this ribbon, grasp the ribbon in the center front "C" on the double spool area. Lift ribbon feeler "A" and push the ribbon sideways to the right side against the spring clips. Repeat the procedure for the rear spools. To install a new ribbon, reverse the procedure. See fig. 6.

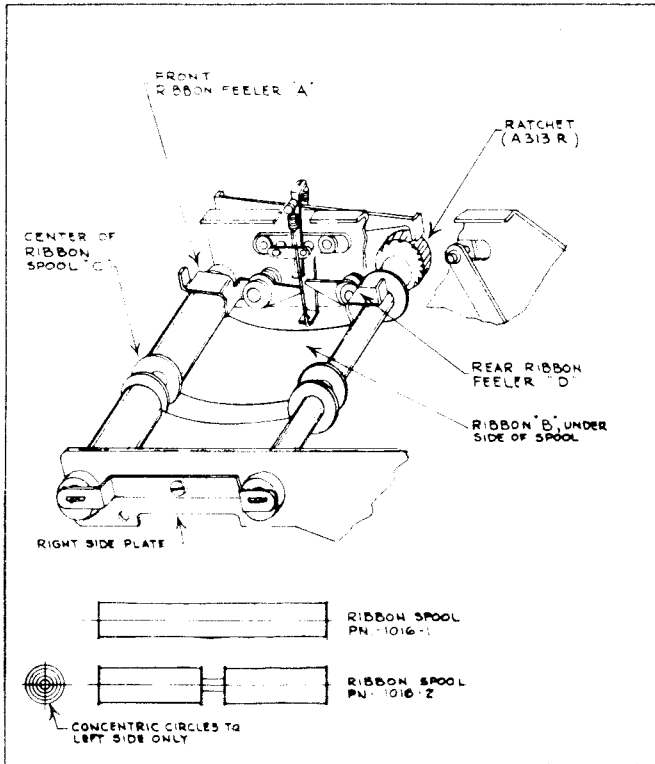

figure 6

Manufacturing Plant and Service Center:
228 Park Street, Hackensack, New Jersey 07601
Tel: (201) 489-3810 (In New Jersey)
Fax: (201) 489-3478
(800) 424-4450 (Outside New Jersey)
Website - www.widmertime.com